

Millermatic® 180 Auto-Set™

Issued September 2010 • Index No. DC/12.44

**MIG Arc Welding Power Source,
Wire Feeder and Gun Package**



Quick Specs

Light Industrial Applications

Light Fabrication
Maintenance and Repair
Auto Body
Farm/Home

Processes

MIG (GMAW)
Flux Cored (FCAW)

Input Power 230 V, 21.7 A, 60 Hz, Single-Phase
Rated Output 135 A at 22.5 VDC, 30% Duty Cycle
Amperage Range 30–180 A
Max. Open-Circuit Voltage 31

The Power of Blue.®

Auto-Set™: The right settings automatically.

- Set the wire diameter, a blue light shows that **Auto-Set™** is activated
- Dial in the thickness of what you're welding
- Start welding with the exact parameters you need!

Infinite voltage control gives you the flexibility to manually set the machine when welding aluminum, stainless steel, or anytime you want to set your own parameters on mild steel.

Welds thickest material in its class!

The Millermatic® 180 Auto-Set™ has the highest output in its class. It can weld from 24 ga–5/16 in (0.8–7.9 mm) mild steel in a single pass.

Spool gun compatible! Finally a reliable and economic way to weld aluminum. Hooked up to a Millermatic® 180 Auto-Set™, the Spoolmate 100 Series spool gun allows you to weld from 18 ga–1/4 in aluminum.

Smooth-Start™ provides a smooth, spatter-free start. It's the best-starting machine in the small MIG machine category. No pop gun starts and no spatter to clean up.

Durable cast-aluminum drive system incorporates dual-groove quick-change drive roll and spring-loaded tension arm with calibrated tension knob, all designed to make set up easier and faster.

Thermal overload protection shuts down unit and activates **over temperature light** if airflow is blocked or duty cycle is exceeded. Automatically resets when fault is corrected and unit cools.



Comes Complete With:

- Power source
- 6 ft (1.8 m) power cord and plug
- 10 ft (3 m) M-100 MIG gun and cable assembly
- 10 ft (3 m) work cable and clamp
- Smith® Argon and AR/CO₂ mix regulator/flow gauge with hose
- Spool of Hobart® .030 in (0.8 mm) solid wire
- Two contact tips for .024 in (0.6 mm) wire and two contact tips for .030 in (0.8 mm) wire
- Dual-groove quick-change drive roll for .024 in (0.6 mm) or .030/.035 in (0.8/0.9 mm) wire
- Factory-installed gas solenoid valve
- Set-up and operation CD
- Information/settings chart
- Material thickness gauge ▶ #229 895

Note: Shielding gas and safety equipment not included.



Easy access to output studs provides **convenient polarity changeover** when changing from solid or flux cored wires.

Miller's **"Tip Saver"** short circuit protection shuts down output when tip is shorted to the work. Extends contact tip life and protects internal components from damage. **Trigger reset** permits quick reset at torch rather than unit.

Standard built-in solid-state contactor circuit makes wire electrically "cold" until trigger is pulled, making the unit safer. It's also easier to position torch to work before starting weld.

Uses 4 or 8 in (102 or 203 mm) spools and can be set up to weld with wire sizes .024–.035 in (0.6–0.9 mm) mild/stainless steel and .030–.045 in (0.8–1.2 mm) flux cored.



Welder is warranted for 3 years, parts and labor. Original main power rectified parts are warranted for 5 years.
Gun warranted for 90 days, parts and labor.

MADE IN **USA**



Miller Electric Mfg. Co.
An Illinois Tool Works Company
1635 West Spencer Street
Appleton, WI 54914 USA

Equipment Sales US and Canada
Phone: 866-931-9730
FAX: 800-637-2315
International Phone: 920-735-4554
International FAX: 920-735-4125

Web Site
www.MillerWelds.com



Specifications (Subject to change without notice.)



Rated Output	Amperage Range	Max. Open-Circuit Voltage	Amps Input at Rated Output, 60 Hz			Wire Feed Speed	Dimensions	Net Weight	Ship Weight
			230 V	KVA	KW				
135 A, 22.5 VDC at 30% Duty Cycle	30-180 A	31	21.7	5.0	4.1	60-540 IPM (1.5-13.7 m/min)	H: 15-3/4 in (400 mm) W: 10-5/8 in (273 mm) D: 17-1/2 in (444 mm)	72 lb (32.7 kg)	81 lb (36.4 kg)

Certified by Canadian Standards Association to both the Canadian and U.S. Standards.

Control Panel

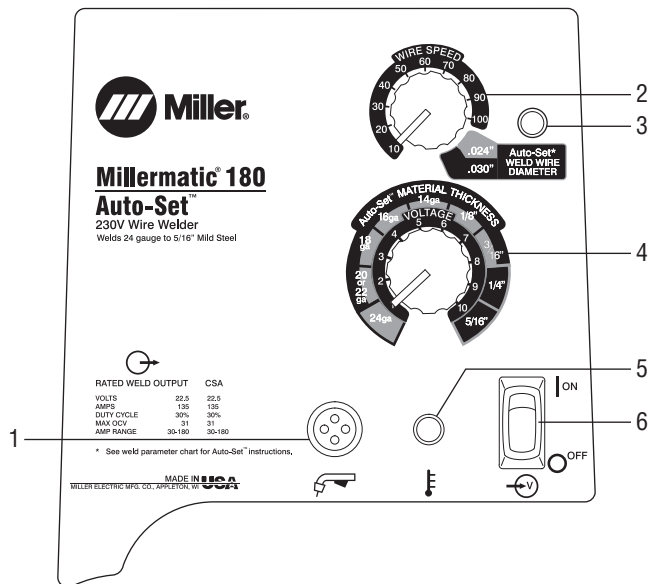

1. Trigger Lead Switch Connection
2. Wire Feed/Wire Diameter Speed Control
3. Auto-Set Light
4. Voltage/Material Thickness Control
5. Over Temperature Light
6. Power Switch

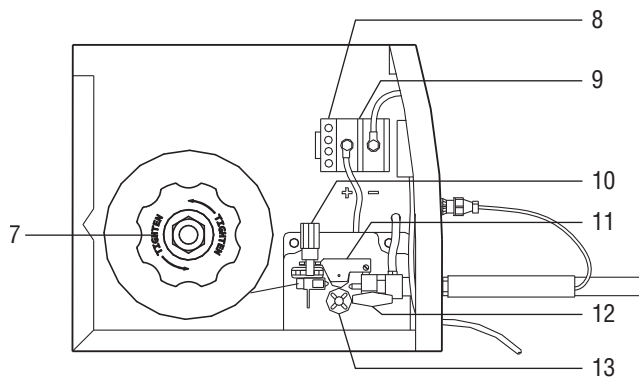

7. Plastic Hub with Retaining Ring for 8 in Spools (shaft also accepts 4 in spools)
8. Storage Holes for Spare Tips
9. Polarity Changeover Terminals
10. Calibrated Tension Knob
11. Springloaded Tension Arm
12. T-Knob (secures torch)
13. Dual-Groove Quick-Change Drive Roll

Performance Data

DUTY CYCLE CHART

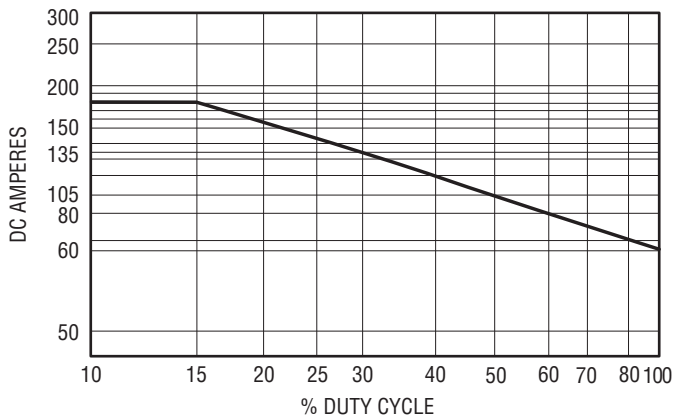

VOLT/AMP CURVES

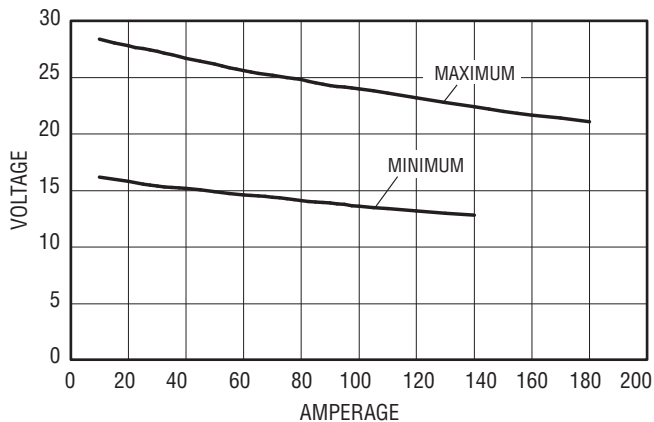

Genuine Miller Accessories



Spoolmate™ 100 Series Spool Gun #300 371

Direct connect spool gun for all Millermatic 140, 180, 211 and Passport Plus models. Handles .030–.035 in (0.8–0.9 mm) aluminum and .023–.035 in (0.6–0.9 mm) steel/stainless steel wires. Rated at 135 amps, 30% duty cycle. Includes 12 ft (3.7 m) cable assembly and custom carrying case.

M-100 Replacement Gun #248 282
10 ft (3 m). Shipped with liner #194 011.



**Millermatic
Protective Cover
#195 149**



**Running Gear/
Cylinder Rack
#770 187**

Heavy-duty construction. Convenient handle on front with cable holders. For gas cylinders no larger than 7 in (178 mm) diameter, maximum weight 100 lb (45 kg).



**Small Running
Gear/Cylinder Rack
#300 425**

Durable construction. For gas cylinders no larger than 7 in (178 mm) diameter, maximum weight 75 lb (34 kg).

Purchase the Millermatic 180 Auto-Set package (#907 312-01-1) and receive the Millermatic 180 Auto-Set and Small Running Gear/Cylinder Rack (#300 425) packaged together!

Consumables (Order from Miller Service Parts.)

For M-100 Gun



Contact Tips

#087 299 .024 in (0.6 mm)
#000 067 .030 in (0.8 mm)
#000 068 .035 in (0.9 mm)
#000 069 .045 in (1.2 mm)



Contact Tip Adapter #169 716



Replacement Liners

#194 010 .024 in
#194 011 .030–.035 in (standard)
#194 012 .035–.045 in



Nozzle #169 715

1/2 in (13 mm) diameter orifice. Nozzle flush with contact tip (standard).



**Gasless Flux Cored
Nozzle #226 190**

For use with self-shielding flux cored wires. Improves visibility, eases access in tight corners, protects tip adapter/gas diffuser from spatter and from shorting to the work piece. For use with the M-100 gun.



Drive Rolls — Quick Change

Dual Groove, V-Smooth #220 179

For .024, .030 and .035 in (0.6, 0.8 and 0.9 mm) wire.

Dual Groove, V-Knurlled #202 926

For .030/.035 in (0.8/0.9 mm) or .045 in (1.2 mm) flux cored wire.



M-Series Gun Consumable Kits

#234 607 .024 in (0.6 mm)

#234 608 .030 in (0.8 mm)

#234 609 .035 in (0.9 mm)

Each kit contains 10 contact tips, 1 nozzle and 1 contact tip adapter.

For Spoolmate™ 100 Series



Contact Tips (5 per package)

#199 730 For .024 in (0.6 mm) wire.
#186 419 For .030 in (0.8 mm) wire.
#186 406 For .035 in (0.9 mm) wire.



Nozzle #186 405



**Drive Roll (1)
#186 413**

For .030/.035 in (0.8/0.9 mm) wire.



**Push Roll (1)
#186 414**

For .030/.035 in (0.8/0.9 mm) wire.

Typical Installations



**MIG (GMAW) or Flux Cored (FCAW)
Basic Equipment**

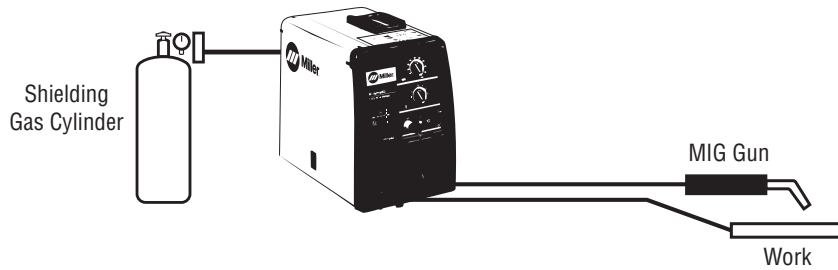

**Aluminum MIG (GMAW)
Basic Equipment**

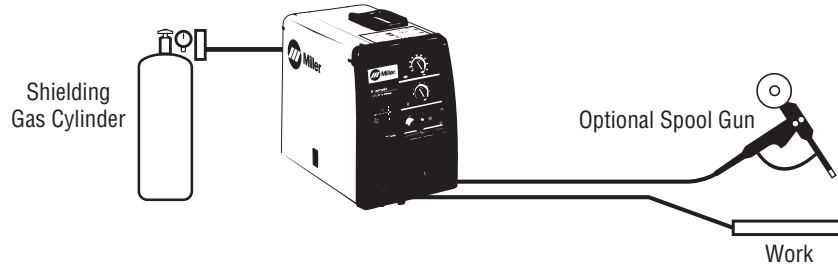

Ordering Information

Equipment and Options	Stock No.	Description	Qty.	Price
Millermatic® 180 Auto-Set™	#907 312	230 V, 60 Hz		
Millermatic® 180 Auto-Set™ with Small Running Gear	#907 312-01-1	Power source packaged with #300 425 Sm Running Gear/Cyl Rack		
Guns				
Spoolmate™ 100 Series Spool Gun	#300 371	Includes 12 ft (3.7 m) cable and custom carrying case		
M-100 Gun	#248 282	10 ft (3 m), .030–.035 in (0.8–0.9 mm)		
Consumables (Order from Miller Service Parts.)				
Contact Tips		See page 3		
Contact Tip Adapter		See page 3		
Replacement Liners		See page 3		
Nozzles		See page 3		
Gasless Flux Cored Nozzle	#226 190			
M-Series Gun Consumable Kits	#234 607	.024 in (0.6 mm)		
	#234 608	.030 in (0.8 mm)		
	#234 609	.035 in (0.9 mm)		
Drive Rolls		See page 3		
Accessories				
Running Gear/Cylinder Rack	#770 187			
Small Running Gear/Cylinder Rack	#300 425			
Protective Cover	#195 149			
CO ₂ Regulator/Flow Gauge	#212 492	Required if using 100% CO ₂ Gas. <i>Order from Miller Service Parts</i>		
Material Thickness Gauge	#229 895			
Flux Cored Wire				
Solid Wire				
Shielding Gas Cylinder				
Helmet/Gloves/Scratch Brush				

Date:

Total Quoted Price:

Distributed by:

